

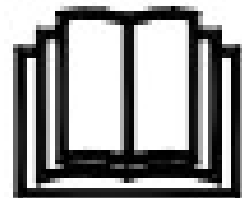

# CLIM8ZONE II – 230V INVERTER Heat Pump for Spas

## User and Service manual

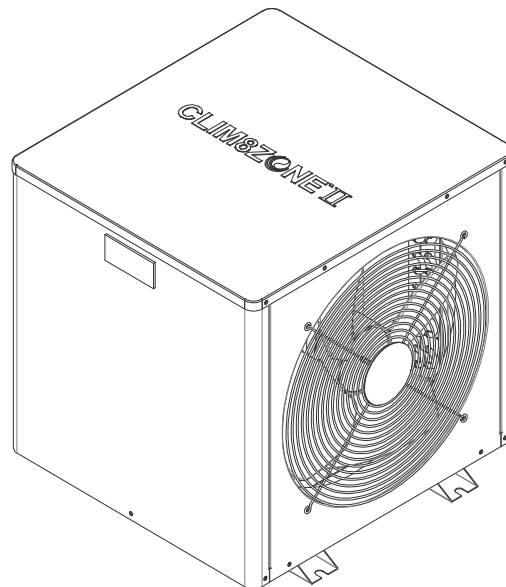

**Spa Heat Pump**



# User and Service Manual (standalone mode)

## INDEX

1. Specifications
2. Dimension
3. Installation and connections
4. Electrical Wiring
5. Display Controller Operation
6. Maintenance

## **SAFETY INSTRUCTIONS:**

**This manual contains all the necessary information for the use and installation of your heat pump**

1. To ensure personal safety and prevent equipment damage, it is important to follow all safety instructions provided on the equipment and within this manual.
2. The installer must read the manual carefully and follow the instructions for installation and maintenance. The installer is responsible for the product's installation and should follow all the manufacturer's instructions and applicable regulations.
3. The manufacturer is not responsible for any damage caused to people, objects, or errors resulting from installation that disregards the manual guidelines.
4. Any use that does not conform to the product's original manufacturing is considered hazardous.
5. The warranty may become void if the equipment is not installed, maintained, or serviced properly. Improper installation contrary to the manual will void the entire warranty.
6. Any use that does not conform to the product's original manufacturing is considered hazardous.
7. Any repair or service of the heat pump should only be carried out by an authorized service center.
8. In case of necessary service, please get in touch with your local sales representative.

## **SAFETY SIGNALS:**

This document contains safety signals placed where specific attention is necessary.



**DANGER:** Disregarding the following instructions will result in serious injury or even death.



**WARNING:** Disregarding the following instructions can result in serious injury or even death.



**NOTICE:** Disregarding the following instructions can result in damage to your heat pump.

When installing and using your heat pump, it is crucial to always follow basic safety precautions. Please take note of the following warnings to ensure the safety of yourself and others.



**DANGERS: Disregarding the following instructions will result in serious injury or even death**

- The heat pump utilizes high voltage and rotating equipment, so use caution when servicing.
- Always turn off the power supply before opening the cabinet to access the interior of the heat pump, as there is high voltage electricity inside.
- This heat pump is equipped with variable frequency compressor drive store electricity even after the power has been deactivated at the power breaker. Wait for 5 minutes after the shutdown of equipment before servicing.
- Follow all National Electric Codes (NEC) and/or State and Local guidelines.



**WARNINGS: Disregarding the following instructions can result in serious injury or even death.**

- Installation and repairs must be performed by a qualified technician.
- The heat pump contains refrigerant under pressure. Repairs to the refrigerant circuit must not be attempted by untrained and/or unqualified individuals. Service must be performed only by qualified HVAC technicians. Recover refrigerant before opening the system.
- Improper water chemistry can present a serious health hazard. To avoid possible hazards, maintain pool/spa water per standards as detailed in hot tub or spa manual instructions.
- Prolonged immersion in water warmer than normal body temperature may cause a condition known as Hyperthermia. People having an adverse medical history or pregnant women should consult a physician before using a hot tub or spa. Children and the elderly should be supervised by a responsible adult.
- Prolonged immersion in water colder than normal body temperature may cause a condition known as Hypothermia. Persons having an adverse medical history or pregnant women should consult a physician before immersing in a cold body of water. Children and the elderly should be supervised by a responsible adult.
- Do not use any methods to speed up the defrosting process or for cleaning, other than those recommended by the manufacturer. The appliance must be stored in a room without continuously operating ignition sources, such as open flames, operating gas appliances, or operating electric heaters. Do not puncture or burn the appliance. It is recommended to install the unit outdoors. If it must be installed indoors, ensure that ventilation is adequate. Please note that refrigerants may not have an odor. NOTE: The manufacturer may provide other suitable examples or additional information regarding refrigerant odors.



**NOTICES: Disregarding the following instructions can result in damage to your heat pump.**

- Maintain proper water chemistry to avoid damage to the pump, filter, hot tub or spa shell, etc.
- Water flow exceeding the maximum flow rate requires a bypass. Damage due to excessive water flow will void the warranty.
- Please ensure to keep the display controller in a dry area to prevent it from being damaged by humidity.
- Always remember to drain the water from the heat pump during winter or when the ambient temperature drops below 0°C. Failure to do so may result in damage to the Titanium exchanger due to freezing, which will void your warranty.

# 1. Specifications

## 1.1 Technical data

230V Clim8zone II – Compact Heat Pump for Spas			
Product model		C8ZII-230V	
Advised spa volume (m <sup>3</sup> ) (with cover)		5-15	
Heating operating ambient temperature range (°C)		-5 ~43	
Cooling operating ambient temperature range (°C)		10 ~40	
Operating water temperature(°C) heating		15~40	
Operating water temperature(°C) cooling		5~35	
Parameters	heating*	Heating capacity (kW)	4.0~1.0
		Heating capacity (BTU/h)	13600~3400
		Input power (kW)	0.8~0.11
		COP	5.0~9.5
	heating**	Heating capacity (kW)	2.5~0.65
		Heating capacity (BTU/h)	8500~2210
		Input power (kW)	0.6~0.1
		COP	4.0~6.1
	Cooling capacity (kW)		1.6
	Maximum current (A)		5.5
	Advised water flow (m <sup>3</sup> /H)		1.72
	IP Grade (Level of protection)		IPX4
	Anti-electric shock Rate		I
	Noise (dB(A)) in 1 meter		≤45
Net weight/Gross weight(kg)		28/30	
Diameter of pipe (mm)		Φ48.3mm (1.5" socket)	
Standard Configuration	Metal plate		Metal Casing
	Body size(W*D*H) mm		496 x 498 x 486
	Refrigerant		R32/260g
	Power supply		220 ~240V/1 Ph/50Hz-60Hz
	Condenser		Titanium in PVC
Remark: heating*: working condition, Inlet water temperature 26°C, Outlet water temperature 28°C, Dry bulb temperature 27°C.Humidity 80%.			
heating**: working condition, Inlet water temperature 26°C, Outlet water temperature 28°C, Dry bulb temperature 15°C. Humidity 70%.			
Cooling: working condition, Inlet water temperature 28°C, Dry bulb temperature 35°C. Humidity 80%.			

## 2. Dimensions (mm)

### 2.1

unit: mm

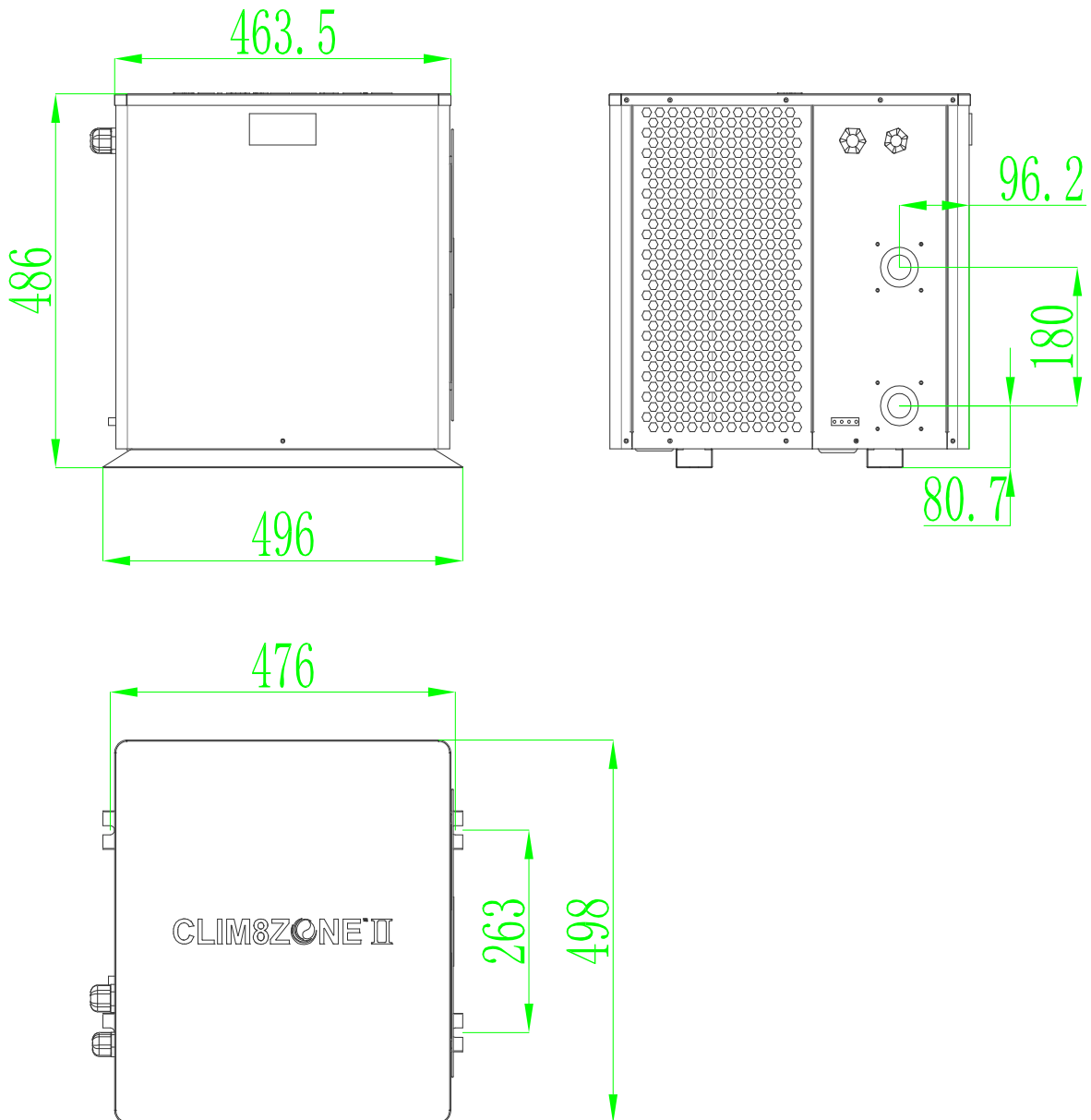

## 2.2 Exploded View

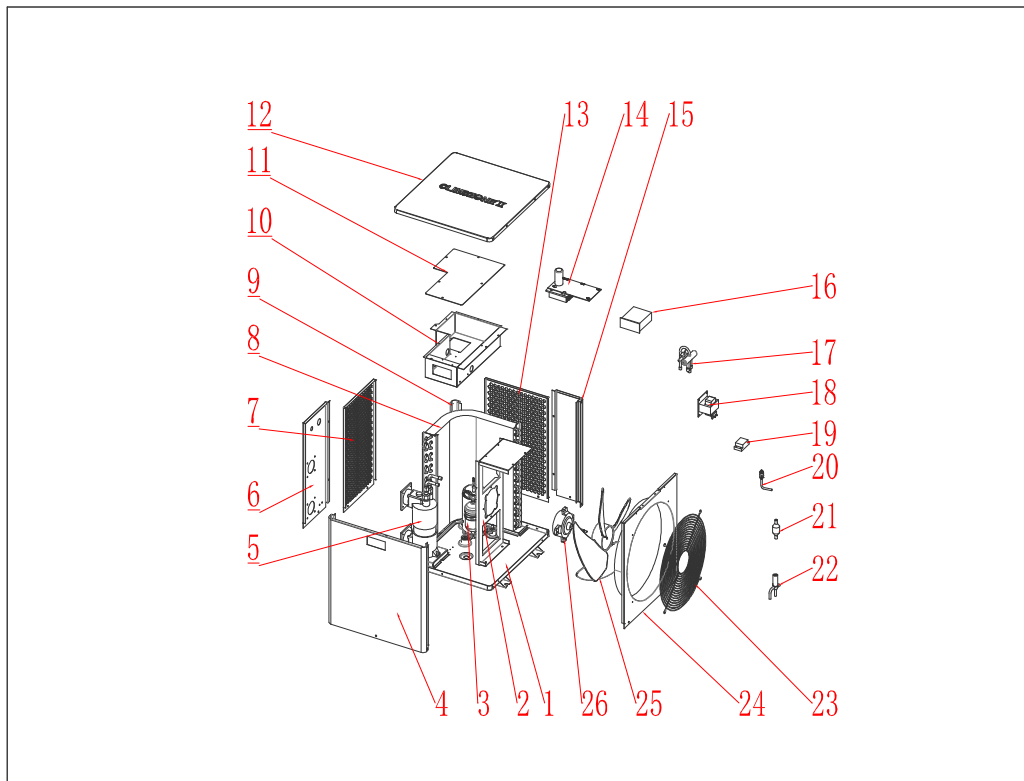

NO	Spare parts	NO	Spare parts
1	chassis	21	filter
2	motor bracket	22	electronic expansion valve
3	compressor	23	fan network
4	front panel	24	air deflector
5	titanium tube heat exchanger	25	fan blade
6	left side panel	26	motor
7	left net		
8	fin heat exchanger		
9	column		
10	electric box		
11	electric box cover		
12	top panel		
13	back net		
14	driver board		
15	rear side panel		
16	control board		
17	4-way valve		
18	reactor		
19	transfer terminal block		
20	needle valve		

### 3. Installation and connections

#### 3.1 Notes

The factory supplies only the heat pump. All other components must be provided by the user or the installer.

Install a bypass if the water flow from the water pump is more than 20% greater than the allowable flow through the heat exchanger of the heat pump.

Always place the heat pump on a solid foundation and use the included rubber mounts to avoid vibration and noise.

Always hold the heat pump upright. If the unit has been held at an angle, wait at least 24 hours before starting the heat pump.

#### 3.2 Heat pump location

The unit will work properly in any desired location as long as the following three items are present:

1. Fresh air
2. Electricity
3. Adequate water flow

The unit may be installed in virtually any **outdoor** location as long as the specified minimum distances to other objects are maintained (see drawing below). To protect the unit from snow and rain, it is suggested to add an open sides shed cover over the heat pump and ensure sufficient ventilation. Please consult your installer for installation with an indoor spa. Installation in a windy location does not present any problem at all, unlike the situation with a gas heater (including pilot flame problems).

#### ATTENTION:

Never install the unit in a closed room with a limited air volume in which the air expelled from the unit will be reused, or close to shrubbery that could block the air inlet. Such locations impair the continuous supply of fresh air, resulting in reduced efficiency and possibly preventing sufficient heat output.

See the drawing below for minimum dimensions.

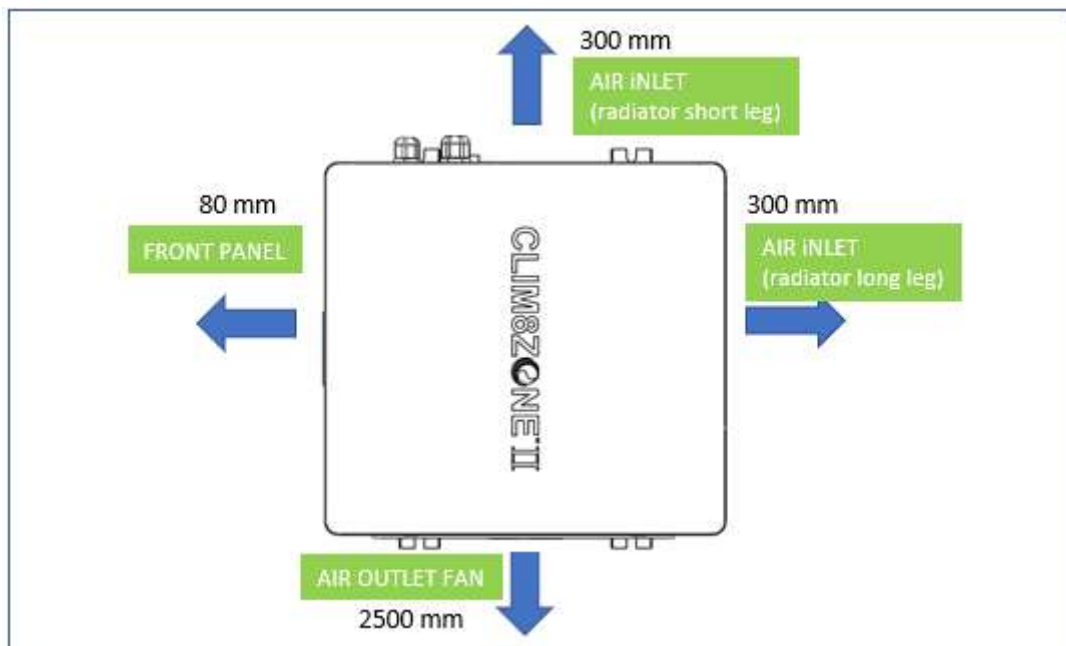

#### 3.3 Distance from your spa

The heat pump is normally installed within a perimeter area extending 2m (6.5ft) from the spa. To minimize heat loss, it is recommended to install the heat pump as close to the spa as possible and add insulations over the pipes connecting the heat pump and the spa.

#### 3.4 Plumbing Connections



### 3.4.1 Plumbing diagram

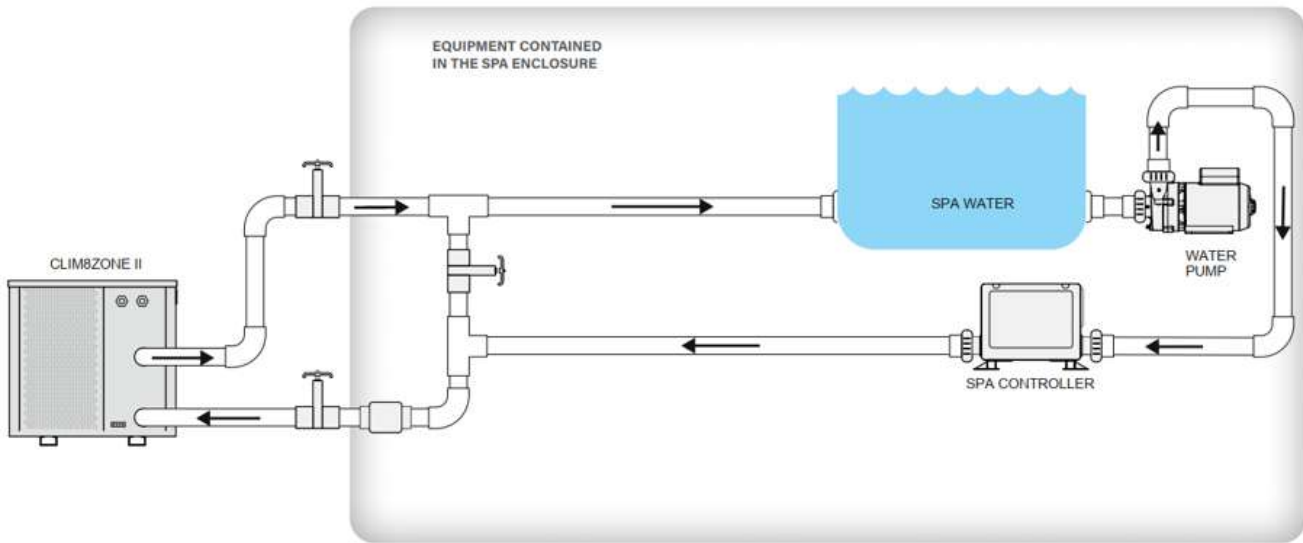

### 3.4.2 Check-valve installation (recommended)

If automatic dosing equipment for chlorine and acidity (pH) is used, it is essential to protect the heat pump against excessively high chemical concentrations which may corrode the heat exchanger. For this reason, equipment of this sort must always be fitted in the piping on the **downstream** side of the heat pump, and it is recommended to install a check-valve to prevent reverse flow in the absence of water circulation.

Damage to the heat pump caused by failure to follow this instruction is not covered by the warranty.

### 3.5 Electrical Connection



**DANGER: Electrical connections below must be done by a qualified and licensed electrician. Failure to do so injury or death may occur.**





1. Turn the spa breaker to OFF position before making electrical connection.
2. Make sure electrical ratings of the power source match with the electrical ratings marked on the label of this unit.
3. Attention: This unit is provided with a grounding lug and must be electrically bonded to the spa common bonding grid. Connect the grounding lug with the spa common bonding grid with a #8 minimum solid copper wire.
4. Power to this unit must be supplied through a residual current device (RCD) having a rated residual operating current not exceeding 30mA.
5. Connect the unit to 230VAC AV port of the spa controller. A splitter (PN 22934, not included) may be needed if the AV port is being used for other equipment.
6. If a spa controller is not used, the unit may be hard wired to the power supply panel and must be done by a licensed electrician.

### 3.6 Initial operation

**Note: In order for the heat pump to operate, the water circulating pump must be running to cause the water to circulate through the heat pump. The heat pump will not start up if the water is not circulating.**

After all connections have been made and checked, follow the following procedure:

1. Switch on the water circulating pump. Check for leaks and verify that water is flowing from and to the spa.
2. Switch on power to the heat pump.

3. Press the  Power button on front panel for 2 seconds.
4. Set the unit to Heat or Cool mode by pressing the  Mode button. Heating = Red LED on. Cooling = Green LED on.
5. Set temperature by pressing  Up or  Down buttons.
6. The unit will start up after the time delay expires.
7. After a few minutes, air will be blowing out of the fan grill.
8. Complete!

**Time delay** - The heat pump has a built-in 3-minute start-up delay to protect the circuitry and avoid excessive contact wear. The unit will restart automatically after this time delay expires. Even a brief power interruption will trigger this time delay and prevent the unit from restarting immediately. Additional power interruptions during this delay period do not affect the 3-minute duration of the delay.

### 3.7 Condensation

In heat mode, the air drawn into the heat pump is greatly cooled by the operation of the heat pump for heating the spa water, which may cause condensation on the fins of the evaporator. The amount of condensation may be as much as several liters per hour at high relative humidity. This is condensation water, not leaked water.

## 4. Electrical Wiring

### 4.1 CLIM8ZONE II HEAT PUMP WIRING DIAGRAM

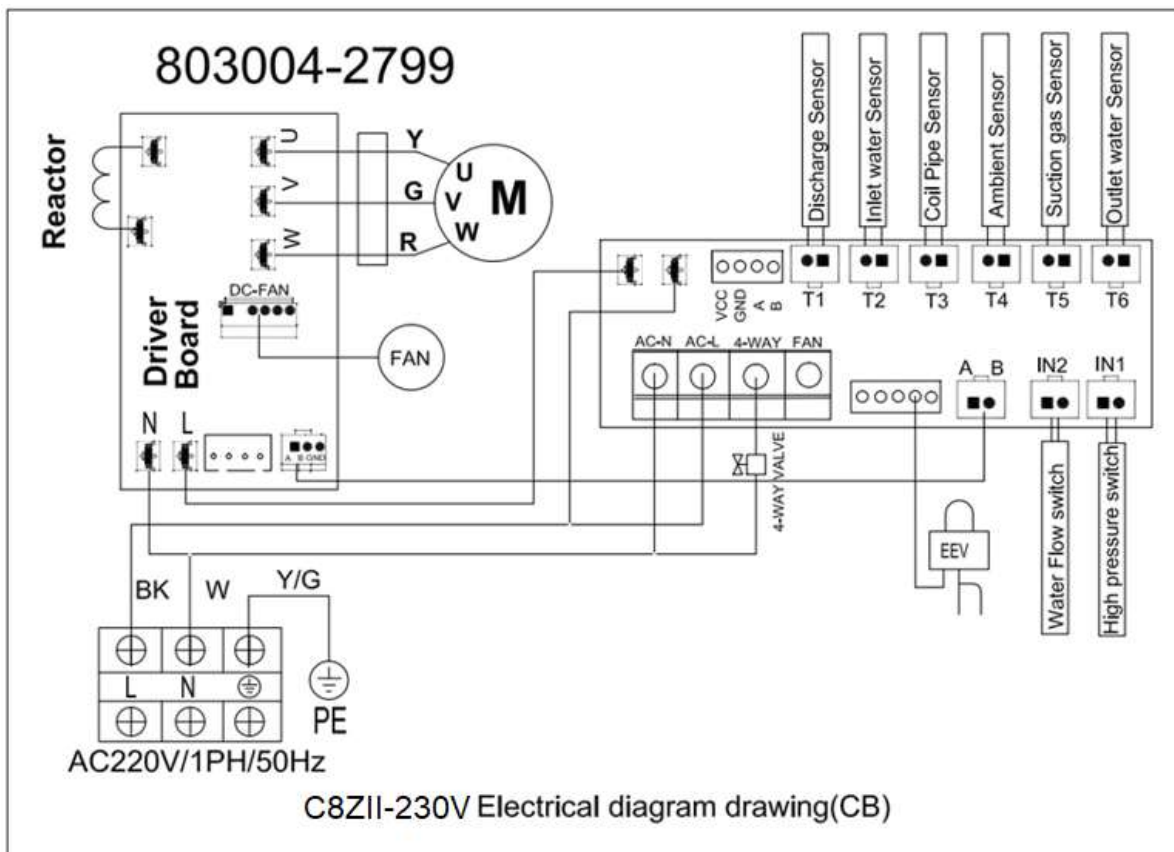

## 5. Controller Panel Operation

### 5.1 Controller Panel Display:

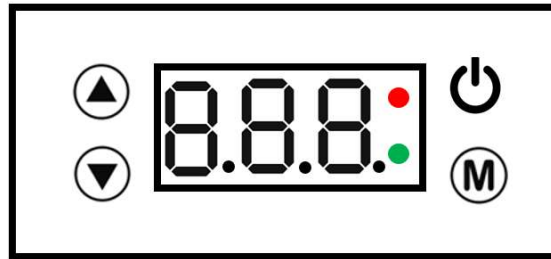

### 5.2 Button Descriptions:

No	Key	Description
1		Turn ON/OFF the controller panel
2		Increase the setting values.
3		Decrease the setting values.
4		Change modes.
5	<b>Red LED On</b>	Heating mode
6	<b>Green LED On</b>	Cooling mode
7	<b>Red LED flashing</b>	Defrosting mode
8	<b>Red &amp; Green LED Off</b>	Heat pump OFF

### 5.3 Operation Instructions:

1. Turn ON/OFF

Press the button for 2 seconds.

2. Mode conversion

Press button to switch heat / cooling mode; Heating =Red LED On ; Cooling = Green LED On.

3. Change temperature unit Fahrenheit/Celsius

Long press three buttons + + at the same time to switch the display of Fahrenheit and Celsius.

4. Forced defrosting

When the outer coil pipe temperature is below the Exit Defrosting Temperature, press two buttons + for 3 seconds to enter the Forced Defrosting.

5. Change Set Temperatures:

Set temperatures can be adjusted by pressing Up or Down buttons.

6. Status Query

To enter the unit status query, press button for 3 seconds to view the temperature parameters. See table



below.

Status Query Table

Query code	Meaning	Display the range
A01	Inlet water temp.	-30~99°C
A01	Outlet water temp.	-30~99°C
A03	Ambient temp.	-30~99°C
A04	Exust temp.	0~125°C
A05	Return gas temp.	-30~99°C
A06	Outer coil temp.	-30~99°C
A08	Electronic expansion valve opening degree	0~480
A10	Compressor current	
A11	Heat-sink temperature	
A12	DC bus voltage value	
A13	Actual compressor speed	
A14	Total main board current	
A15	DC fan speed	0~1590
A16	<b>Unit operation mode</b>	<b>0: AP* mode/1: BP** mode</b>





\* AP = Standalone; \*\* BP = Integrated with Balboa BP Spa Controller

#### 7. Change Unit operation mode













Long press two buttons  and  for 15 seconds at the same time to switch between AP and BP modes;

A16: = 0 heat pump operates in AP mode; A16 = 1: heat pump operates in BP mode.

#### 5.4. Query and setting of the system parameters

Query: Press  button for 3 seconds to enter the parameter query state. Press  or  button to switch from one parameter to another. Press  button to view the value of the parameter. Press  button to return and exit the query.

Modify: To modify the parameter, a password will be needed. The password is 68. Follow the below procedure:

- Long press  and  button to enter the input password interface,
- Press  button to enter the first password digit "6" by pressing  or  buttons,
- Press  button to advance to the second password digit and enter "8" by pressing  or  buttons,
- Press  button to submit the password. After entering, select or change parameters by using  or  buttons
- Press  button to make entry changes or confirm and return to the viewing status.

System parameter table

Parameter code	Parameter name	Adjust range	Default value
P01	Return Difference for Target Water Temp.	1°C~18°C	1°C
P02	Reserved	--	--
P03	Reserved	--	--
P04	Cooling setting temp.	8°C~28°C	27°C
P05	Heating setting temp.	15°C~40°C	27°C
P06=TP4	The setting temp. that Exhaust temp. too high protection	80°C~125°C	110°C
P07=TP0	Recover The setting temp. from the too high exhaust temp.	50°C~100°C	90°C
P08	Compressor current protection	2A~50A	Reserved--Without this function
P09	Inlet water temp. compensation	-5°C~15°C	0°C
P10	Reserved	--	--
P11	Defrosting cycle	20MIN~90MIN	40MIN
P12	Defrosting enters the temp.	-15°C~-1°C	-3°C
P13	Defrosting time	2MIN~20MIN	5MIN
P14	Desrosting exit temperature	1°C~40°C	18°C
P15	Temp. difference between defrosting environment and coil pipe	0°C~15°C	9°C
P16	Ambient temperature of the defrosting	0°C~20°C	17°C
P17	Expansion valve cycle	20-90	30
P18	Overheat Degree in Heating Mode	-5-10	3
P19	Main valve set exhaust gas	70-125	95
P20	Main valve defrosting opening degree	2-45	30
P21	Minimum opening degree of the main valve	5-15	8
P22	Expansion valve mode	0 Manual / 1 Automatic	1
P23	Manual steps of the main valve	2-45	35
P24	Cooling opening degree of the main valve	2-45	30

### 5.5. Error Code table:

Error code	Error description	description	Solution suggestion
E03	Water flow failure	<ol style="list-style-type: none"> <li>1. The water flow switch fault</li> <li>2. Low water flow</li> <li>3. The inlet and outlet water are reversed</li> <li>4. There is air in the pipe</li> <li>5. The pipe blocked</li> </ol>	<ol style="list-style-type: none"> <li>1. Check the water flow switch and replace it if it is faulty</li> <li>2. Check the water valve and the temperature difference between inlet and outlet water</li> <li>3. Whether the inlet and outlet water pipes are correctly connected</li> <li>4. Emptying</li> <li>5. Pipe cleaning</li> </ol>
E04	winter anti-freezing	The ambient temperature is lower than the antifreeze setting value	Normal protection procedure
E05	High pressure protection	<ol style="list-style-type: none"> <li>1. Low water flow</li> <li>2.. Pressure switch fault</li> <li>3. The fan motor unwork or the speed too low</li> <li>4. Overcharged the refrigerant</li> </ol>	<ol style="list-style-type: none"> <li>1. Check whether the temperature difference between inlet and outlet water is too large, and whether the outlet water temperature is too high</li> <li>2. Use a multimeter to check whether the high voltage protection switch works</li> <li>3. Check the water flow of the water pump and the speed of the fan</li> <li>4. Refill the refrigerant</li> </ol>
E09	Communication with the upper computer failed ( Communication with Balboa system failed)		<ol style="list-style-type: none"> <li>1. Replace the main board</li> <li>2. Check the communication cables between the main board and Balboa system</li> <li>3. Check whether the Balboa system software matches</li> </ol>
E10	Communication fault of frequency conversion module (alarm when communication is disconnected between external board and drive board)	<ol style="list-style-type: none"> <li>1. The mainboard or driver board damaged</li> <li>2. The connector of the communication cable between the mainboard and the driver board is in poor contact or falls off</li> <li>3. The communication cable is</li> </ol>	<ol style="list-style-type: none"> <li>1. Replace the main board or driver board</li> <li>2. Check the communication cables between the main board and driver board</li> <li>3. Replace the communication cable</li> </ol>

		damaged	
E12	Exhaust too high protection	1. Less refrigerant or leakage 2. The system blocked 3. Compressor refrigerant oil is insufficient 4. The resistance value of the exhaust probe is offset, and the inlet temperature probe is dropped	1. Refill the refrigerant 2. Replace the filter 3. Add refrigerant oil to the compressor 4. Replace the exhaust probe and reconnect the water inlet temperature probe
E15	Inlet water temp. Error	The sensor plug is in poor contact or off, or the sensor is damaged	Check and replace the water inlet temperature sensor(T2 sensor)
E16	Outer coil pipe temp. Error	The sensor plug is in poor contact or off, or the sensor is damaged	Check and replace the coil pipe temperature sensor(T3)
E18	Exhaust gas temp. Error	The sensor plug is in poor contact or off, or the sensor is damaged	Check and replace the exhaust gas temperature sensor(T1)
E20	Abnormal protection of frequency conversion module	IPM module internal fault, check related problems according to the attached table	
E21	Ambient temp. Error	The sensor plug is in poor contact or off, or the sensor is damaged	Check and replace the ambient temperature sensor(T4)
E27	Outlet temperature fault	The sensor plug is in poor contact or off, or the sensor is damaged	Check and replace the water outlet temperature sensor(T6)
E29	Return gas temp. Error	The sensor plug is in poor contact or off, or the sensor is damaged	Check and replace the suction gas sensor(T5)
E46	DC Fan Error	1.Dc fan failure 2.Plug is in poor contact or off	1. Replace the DC fan 2. Reconnect cables to the DC fan

E20 fault will display the following error codes at the same time, the error codes will switch every 3 seconds. Among them, error codes 1-128 are displayed in priority.

When error codes 1-128 don't appear, then error codes 257-384 can show.

If two or more error codes appear at the same time, then display error codes accumulation.

For example, 16 and 32 occur at the same time, display 48.

Error Code	name	description	Solution suggestion
1	IPM Over-current	1. The IPM overloaded or overheated 2. The U,V,W driver short-circuited 3. The IPM module fault 4. The compressor damaged	1 Ensure that the ring temperature, water temperature, water flow, etc. are within the operating range of the unit; 2. Use a multimeter to measure

			<p>the motor U,V,W in ohmic gear to ensure no short circuit</p> <ol style="list-style-type: none"> <li>3. Replace the frequency conversion module</li> <li>4. Replace the compressor</li> </ol>
2	compressor synchronous abnormal	<ol style="list-style-type: none"> <li>1. The compressor overloaded instantaneously</li> <li>2. The compressor does not match the program</li> <li>3. The difference between high and low pressure starts the compressor excessively</li> </ol>	<ol style="list-style-type: none"> <li>1. Ensure that the ring temperature, water temperature, water flow, etc. are within the operating range of the unit;</li> <li>2. Replace the driver board with the correct program</li> <li>3. Ensure that the high and low pressure difference starts normally</li> </ol>
8	compressor output phase absent	<ol style="list-style-type: none"> <li>1. The U, V, and W cables of the compressor are missing or improperly connected</li> <li>2. The compressor does not match the program</li> <li>3. The difference between high and low pressure starts the compressor excessively</li> </ol>	<ol style="list-style-type: none"> <li>1. Check whether the U, V, and W wires of the compressor are missing or in poor contact</li> <li>2. Update the driver</li> <li>3. Ensure that the high and low pressure difference starts normally</li> </ol>
16	DC bus low voltage	<ol style="list-style-type: none"> <li>1. The power supply unstable</li> <li>2. AC suddenly power off, the inverter capacitor residual power supply chip detects that the DC voltage will be too low</li> <li>3. The PFC module fault</li> </ol>	<ol style="list-style-type: none"> <li>1. Ensure that the power supply is stable</li> <li>2. Check the capacitor after it is powered off</li> <li>3. Replace the faulty frequency conversion module</li> </ol>
32	DC bus high voltage	<ol style="list-style-type: none"> <li>1. The power supply voltage too high.</li> <li>2. The capacitor fault</li> <li>3. The PFC module fault</li> </ol>	<ol style="list-style-type: none"> <li>1. Ensure that the power supply voltage is normal</li> <li>2. Replace the capacitor</li> <li>3. Replace the faulty frequency conversion module</li> </ol>
64	Radiator over temperature	<ol style="list-style-type: none"> <li>1. The fan on the host is faulty</li> <li>2. The air duct is blocked</li> </ol>	<ol style="list-style-type: none"> <li>1. Check and replace the fan</li> <li>2. Ensure proper ventilation</li> </ol>
128	Radiator temperature error	<ol style="list-style-type: none"> <li>1. The heat sink sensor is short-circuited or open</li> <li>2. Heat sink fouling</li> <li>3. The ambient temperature too high</li> </ol>	<ol style="list-style-type: none"> <li>1. Replace the frequency conversion module</li> <li>2. Remove dust and scale from the heat sink</li> <li>3. Lower the ambient temperature</li> </ol>
257	communication failure	<ol style="list-style-type: none"> <li>1. The connector of the</li> </ol>	<ol style="list-style-type: none"> <li>1. Reconnect and ensure</li> </ol>



		<p>communication cable between the mainboard and the driver board is in poor contact or falls off</p> <p>2. Internal components of the heat pump damaged</p> <p>3. The output voltage of the power supply board in the module abnormal or no output</p>	<p>stability</p> <p>2. Replace the internal components</p> <p>3. Replace the power module</p>
264	AC Input low voltage	<p>1. The input voltage too low</p> <p>2. The current transformer damaged during transportation</p>	<p>1. Ensure that the input voltage is normal</p> <p>2. Ensure that the current transformer works properly</p>
288	IPM too high temperature	<p>1. The fan is faulty or the air duct blocked</p> <p>2. The ring temperature rises too fast, resulting in over-temperature drop too late to react</p> <p>3. The power supply voltage and current too high or too low</p>	<p>1. Replace the fan</p> <p>2. Ensure that the air duct unblocked</p> <p>3. Reduce the ring temperature</p> <p>4. Ensure that the power supply voltage and current are normal</p>
320	Compressor peak current too high	<p>1. Compressor load is too large;</p> <p>2. The driver board is faulty</p> <p>3. The compressor is damaged</p>	<p>1. Ensure that the ring temperature, water temperature, water flow, etc. are within the operating range of the unit;</p> <p>2. Replace the compressor driver plate.</p> <p>3. Replace the compressor</p>

## 6. Maintenance

1. Check the water supply system regularly to avoid the air trapped in the system and occurrence of low water flow, because it would reduce the performance and reliability of heat pump.
2. Clean your spa and filtration system regularly to avoid the damage of the unit as a result of the dirty or clogged filter.
3. Remove all water from the heat pump if it will not be used for a long period of time (especially during the winter).
4. After the unit has been properly winterized, it is recommended to cover the heat pump with special winter cover.
5. After a long winter shutdown, before start to run the heat pump again, make sure the spa is filled with fresh and clean water and all valves to the heat pump are open.
6. When the unit is running, there is all the time some water discharged under the unit.
7. Clean the outside of the heat pump regularly.